

 **mohest kit**[®]
Automation for swing gates
Автоматика для распашных ворот التشغيل الآلي للسوينغ بوابات



TECHNICAL FEATURES

	Mohest 3	Mohest 4	Mohest 5
Power supply	230 - 50Hz		
Absorption	1.2 - 1.7 A		
Motor power	280W		
Capacitor	8 μ f		
Thermic protection	150°		
Maximum thrust	2800n		
IP level	44		
Revolutions speed	1400 g/m		
Working temperature	-20° - +55°C		
Leaf's maximum length	2.00 m	2.75 m	3.50 m
Leaf-s maximum weight	350 Kg	350 Kg	250 Kg
Standard stroke	300 mm	400 mm	500 mm
Maximum Opening	110°		
90 opening time	17"	22"	27"
Duty cycle	40%		

OPERATIONAL DIAGRAM

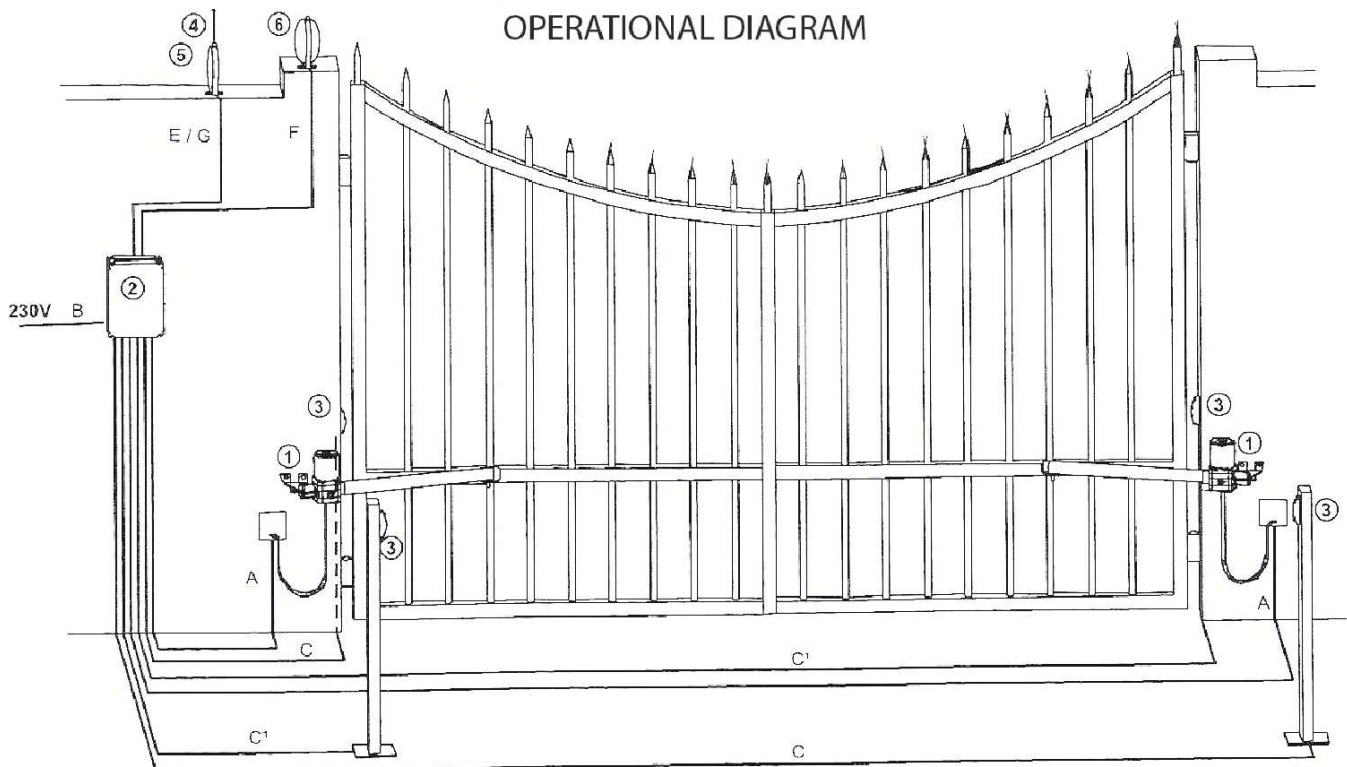

230 V

1	Operator	A	3 x 1,5+T
2	Electronic unit	B	2 x 1,50+T
3	Photocells	Rx	C
		Tx	C'
4	Aerial	F	COASSILE
5	Radio Receiver	G	4 x 0.75
6	Warning light	F	2 x 1.5

COMPOSITION

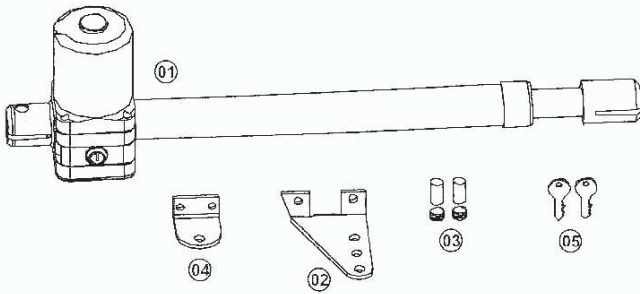

01	n°1	Actuator
02	n°1	Bracket
03	n°1	Fixing kit
04	n°1	Bracket
05	n°2	Release key
	n°1	Installation and Use Manual
	n°1	General Instructions manual

DIMENSIONS

MOHEST

	A	A1
MOHEST 3	665	965
MOHEST 4	765	1165
MOHEST 5	865	1365

TABLE 1

	200 mm	175 mm	150 mm	125 mm	100 mm	75 mm	50 mm
MOHEST 3	/ /	/ /	A = 98 B = 202 S1	A = 123 B = 177 S1	A = 148 B = 152 S1	A = 143 B = 157 S1	A = 168 B = 132 S1
MOHEST 4	A = 148 B = 252 S1	A = 173 B = 227 S1	A = 198 B = 202 S1	A = 193 B = 207 S1	A = 218 B = 182 S1	A = 213 B = 187 S1	A = 205 B = 195 S2
MOHEST 5	A = 248 B = 252 S1	A = 243 B = 257 S1	A = 268 B = 232 S1	A = 263 B = 237 S1	A = 255 B = 245 S1	A = 280 B = 220 S2	A = 305 B = 195 S2

Mohest 3 A= 145 B= 145

Mohest 4 A= 195 B= 195

Mohest 5 A= 245 B= 245

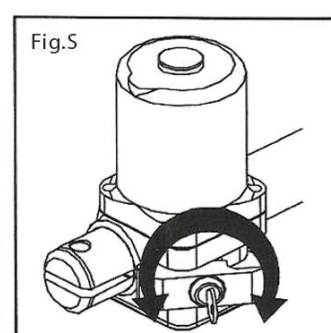
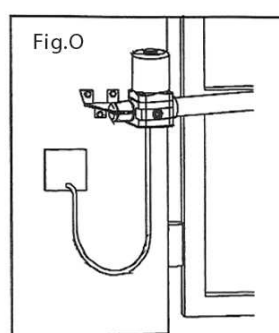
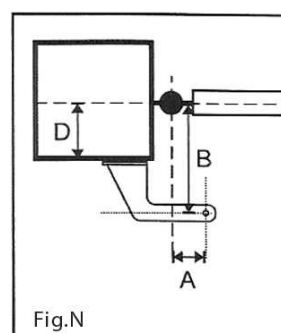
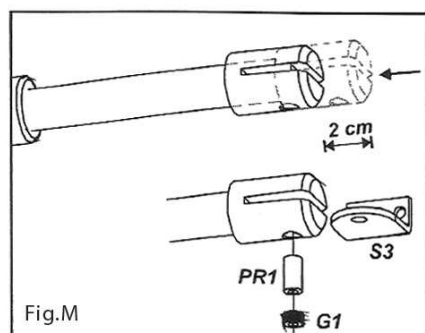
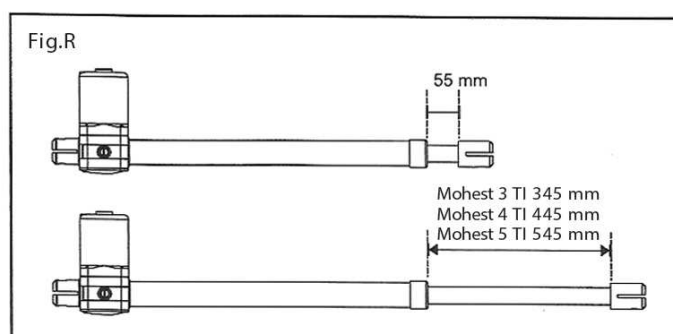
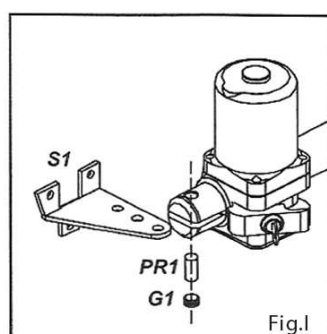
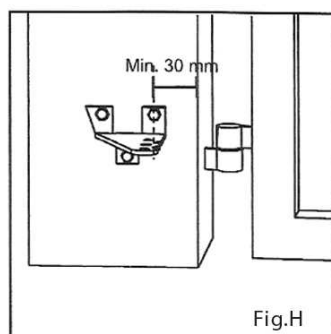
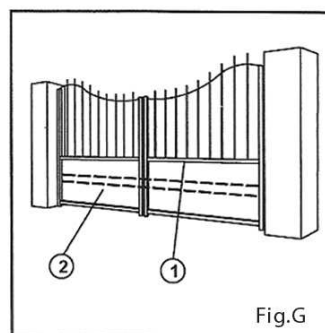
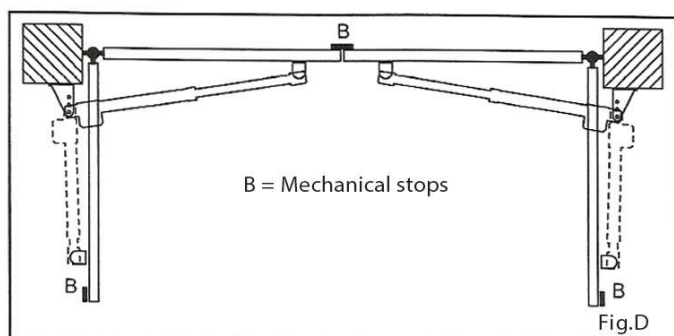
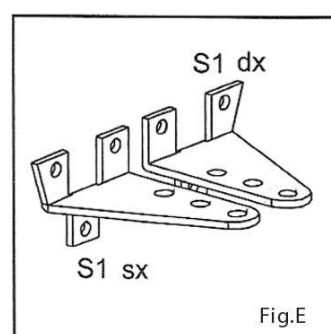
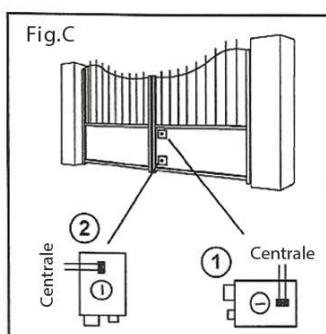
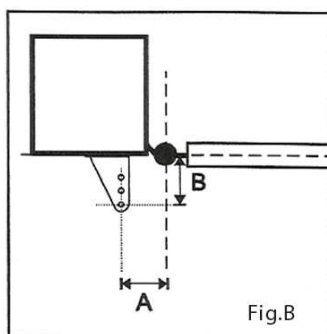
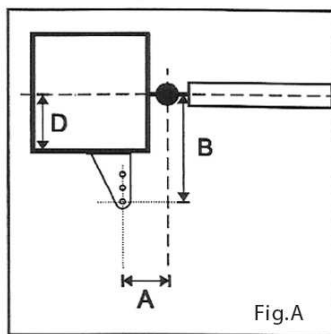

سیم کشی چشمی
 مثبت برد گیرنده به سوکت شماره ۸
 مثبت برد فرستنده به سوکت شماره ۹
 منفی مشترکا به سوکت شماره ۱۰
 فرمان برد گیرنده با شکل ۶ به سوکت شماره ۳
 فرمان برد گیرنده با شکل ۳ به سوکت شماره ۸

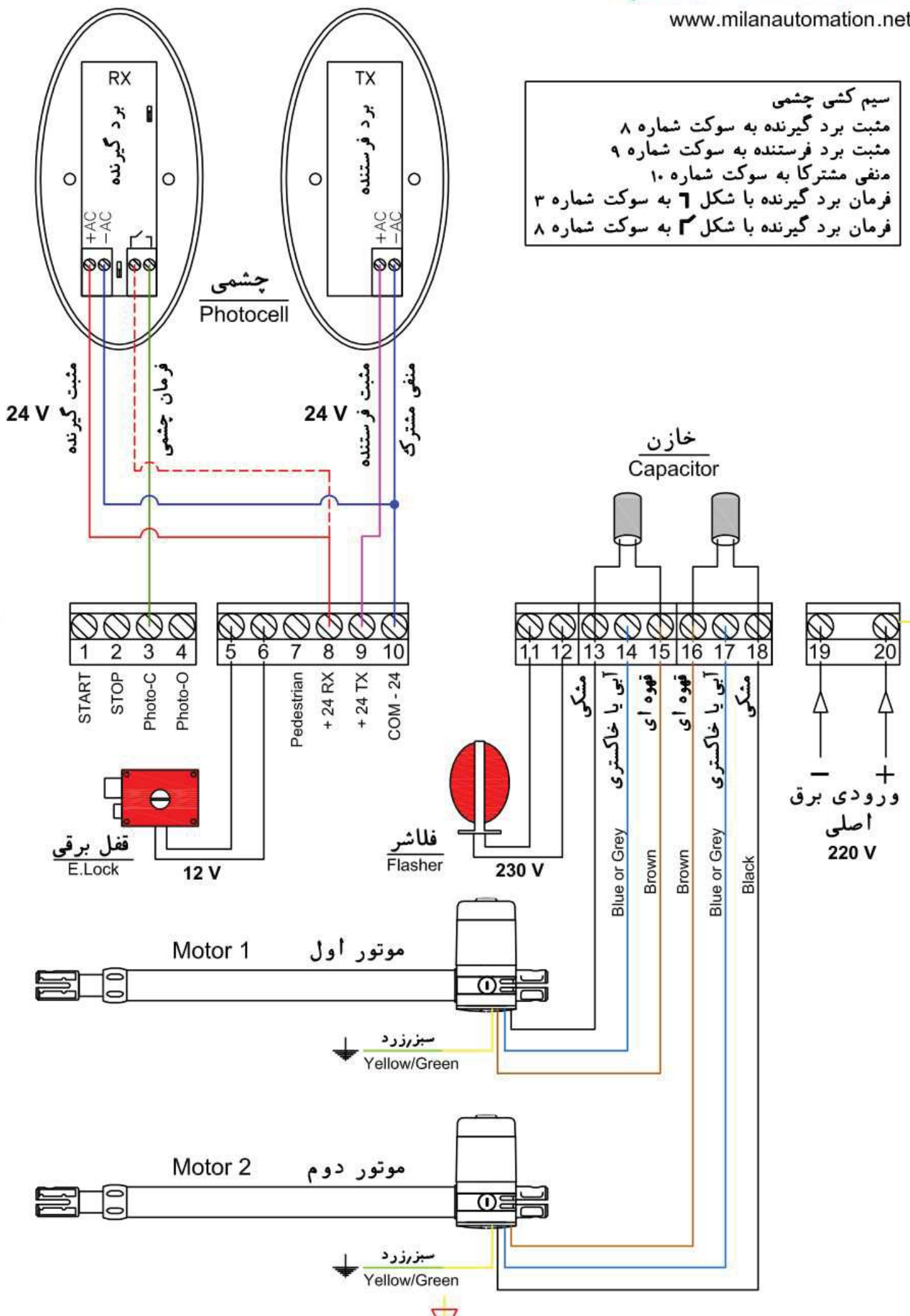

ورودی برق اصلی
 220 V